

MODEL TUB BELT DRIVEN TUBEAXIAL UPBLAST POWER ROOF EXHAUSTER

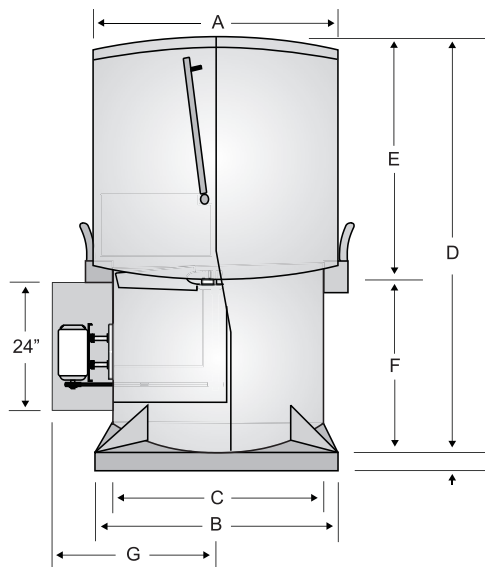

STANDARD FEATURES

- Heavy-gauge welded galvanized construction.
- Statically and dynamically balanced propeller.
- Variable pitch drive (thru 3HP).
- Drives sized for 150% of motor HP.
- 1 year fan & motor warranty.
- Motor & drives out of the airstream.
- 200,000 hour pillow block ball bearings.
- Butterfly damper doors.
- Factory run and tested.
- Integral lifting lugs.

SIZE	A	B sq.	C sq.	D	E	F	G (Max.)	METAL GAUGES		
								FAN HOUSING	WIND SHROUD	CURB CAP
24	30	35	25-1/8	55-1/2	25	30-1/2	37	12	18	14
30	36	41	31-1/8	58-1/2	28	30-1/2	40	12	18	14
36	42	47	37-1/8	60-1/2	30	30-1/2	43	12	18	14
42	48	53	43-1/8	65-1/2	33	32-1/2	46	12	18	14
48	54	59	49-1/8	68-1/2	36	32-1/2	49	10	18	14
54	60	65	55-1/8	71-1/2	39	32-1/2	52	10	18	14
60	66	71	61-1/8	74-1/2	42	32-1/2	55	10	18	10

FAN SPECIFICATIONS									MOTOR SPECIFICATIONS				
Line	Qty.	Model No.	Tag	CFM	SP	Fan RPM	BHP	Sones	HP	Volts	Phase	Hertz	Encl
1													
2													
3													
4													
5													

ACCESSORY ITEMS					ACCESSORY ITEMS						
	1	2	3	4	5		1	2	3	4	5
<input type="checkbox"/>						<input type="checkbox"/>					
<input type="checkbox"/>						<input type="checkbox"/>					
<input type="checkbox"/>						<input type="checkbox"/>					
<input type="checkbox"/>						<input type="checkbox"/>					
<input type="checkbox"/>						<input type="checkbox"/>					

Project: _____ Submitted: _____
 Customer: _____ Approved: _____
 Location: _____

MODEL TUB-HT BELT DRIVEN TUBEAXIAL UPBLAST POWER VENTILATOR FOR SMOKE CONTROL SYSTEMS

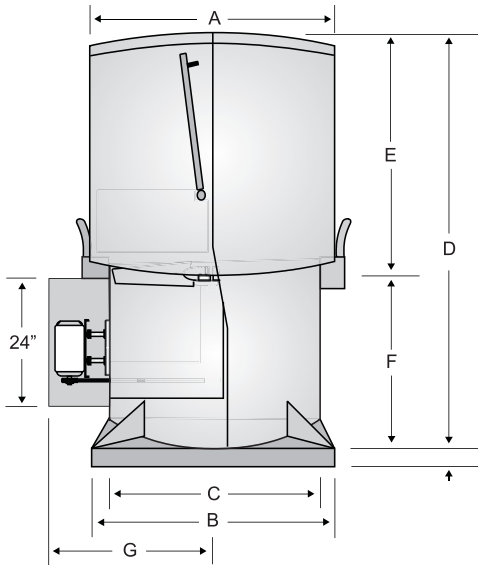

STANDARD FEATURES

- High Temp (Model TUB-HT).
- Heat tested to: 1000° 15 minutes
500° 4 hours - IRI/SBCCI
- UL-793 listed Power Ventilator for Smoke Control Systems (optional).
- Meets the requirements of UL-793 snow load test.
- All ferrous construction in airstream.
- 165°F fusible link in damper release mechanism (heat & smoke vent).
- Motor out-of-airstream.
- Belt & bearing enclosed in ventilated housing.
- Shaft heat slinger.
- Dual groove drive up to 10HP, three groove on 15HP units.
- Extended lube line.
- Integral lifting lugs.



Standard 793
(optional)

SIZE	A	B sq.	C sq.	D	E	F	G (Max.)	METAL GAUGES		
								FAN HOUSING	WIND SHROUD	CURB CAP
24	30	35	25-1/8	55-1/2	25	30-1/2	37	12	18	14
30	36	41	31-1/8	58-1/2	28	30-1/2	40	12	18	14
36	42	47	37-1/8	60-1/2	30	30-1/2	43	12	18	14
42	48	53	43-1/8	65-1/2	33	32-1/2	46	12	18	14
48	54	59	49-1/8	68-1/2	36	32-1/2	49	10	18	14
54	60	65	55-1/8	71-1/2	39	32-1/2	52	10	18	14
60	66	71	61-1/8	74-1/2	42	32-1/2	55	10	18	10

FAN SPECIFICATIONS									MOTOR SPECIFICATIONS				
Line	Qty.	Model No.	Tag	CFM	SP	Fan RPM	BHP	Sones	HP	Volts	Phase	Hertz	Encl
1													
2													
3													
4													
5													

ACCESSORY ITEMS					ACCESSORY ITEMS						
	1	2	3	4	5		1	2	3	4	5
<input type="checkbox"/>						<input type="checkbox"/>					
<input type="checkbox"/>						<input type="checkbox"/>					
<input type="checkbox"/>						<input type="checkbox"/>					
<input type="checkbox"/>						<input type="checkbox"/>					
<input type="checkbox"/>						<input type="checkbox"/>					

Project: _____ Submitted: _____
 Customer: _____ Approved: _____
 Location: _____